

The Maths of Sandcastles

Have you ever wondered about how to build a great sandcastle? When you next visit the beach, see if you can make a structure which stands longer than anyone else's – you could even challenge your friends! You would be amazed at some of the structures which can be built when the water-to-sand ratio of the mixture is just right.

Suggested equipment:

- measuring jug/bucket
- spade
- tape measure
- stop watch



To begin your experiment, decide on the shape of the castle. If you aim for the same shape each time, you have comparable results. You may wish to time how long the castle stands for, or simply make general observations of the structure. An example has been given to you.

Water:Sand	Comments
1:3	The mixture held together well, but was too wet to build up to the desired height.



Once you have decided on the best water:sand ratio, you may begin experimenting with different structures. Again, an example has been given to you.

Height	Width	Depth	Description	Comments
40cm	60cm	30cm	A square-based castle with two cylindrical towers.	The towers seemed to crumble very quickly and needed more water.

When you have finished experimenting, attach an image of the optimum sandcastle.

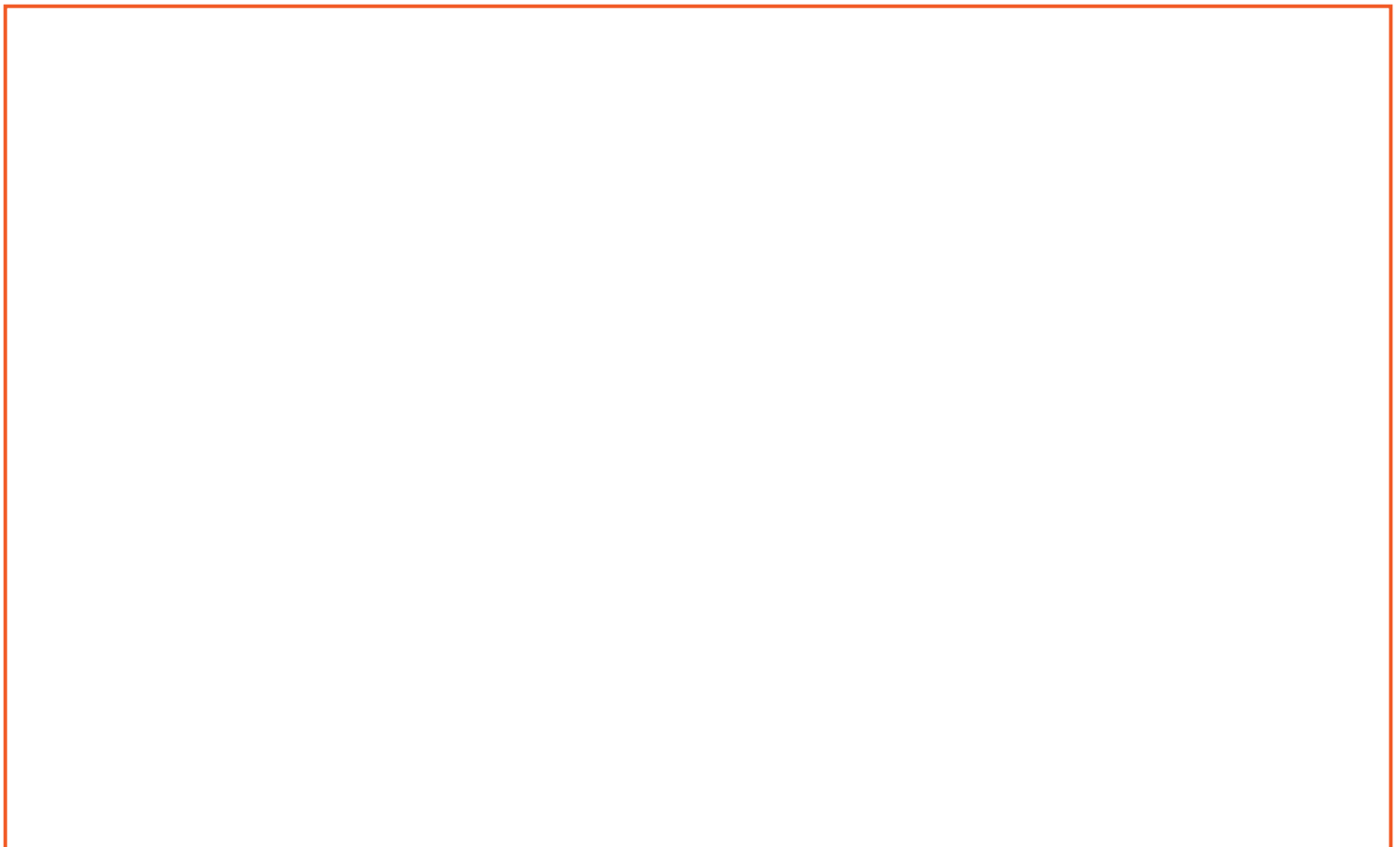

The Maths of Sandcastles Extension

Density of water = 1kg/litre

Density of sand = 1602 kg/m³

1. Convert the density of water into kg/m³.
2. Calculate the volume of the symmetrical sandcastle shown. Give your answer to 3 decimal places with a suitable unit.
3. If the castle is made from a mixture of water and sand in the ratio 1:4, what is its mass? Give your answer to 3 decimal places.
4. Sanjay makes the castle as shown from a mixture of water and sand in the ratio 1:4. His friend Burt makes the castle without one of the cylindrical towers from a mixture of water and sand in the ratio 1:6. Which castle has the greatest mass?

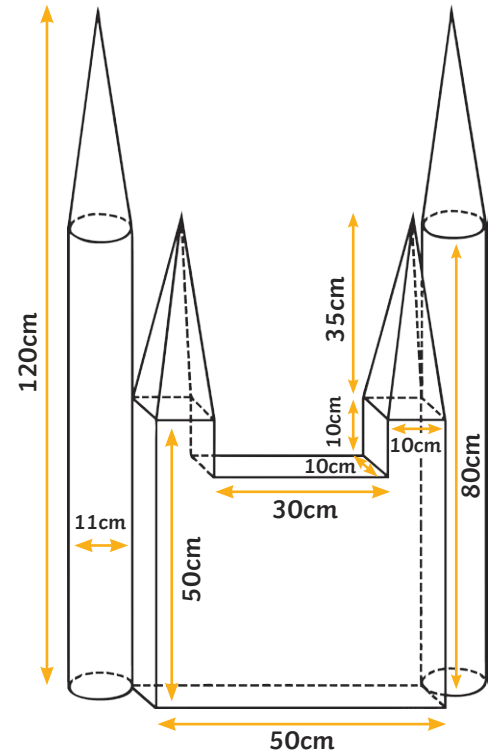

The Maths of Sandcastles Extension Answers

1. Convert the density of water into kg/m^3 .

$$1\text{kg/litre} = 1 \times 1000$$

$$\text{Density} = 1000 \text{ kg/m}^3$$

2. Calculate the volume of the symmetrical sandcastle shown. Give your answer to 3 decimal places with a suitable unit.

Volume of the two cylinders:

$$\bullet \quad v = \pi \times 5.5^2 \times 80$$

$$\bullet \quad v = 7602.654222 \times 2$$

$$\bullet \quad v = 15\,205.30844\text{cm}^3$$

Volume of the two cones:

$$\bullet \quad v = \frac{1}{3}(\pi \times 5.5^2 \times 40)$$

$$\bullet \quad v = 1267.10937$$

$$\bullet \quad v = 1267.10937 \times 2$$

$$\bullet \quad v = 2534.218074\text{cm}^3$$

Volume of the two square-based pyramids:

$$\bullet \quad v = \frac{1}{3} \times 10^2 \times 35$$

$$\bullet \quad v = 1166.6$$

$$\bullet \quad v = 1166.6 \times 2$$

$$\bullet \quad v = 2333.3\text{cm}^3$$

Volume of the cuboid:

$$\bullet \quad v = (50 \times 10 \times 50) - (30 \times 10 \times 10)$$

$$\bullet \quad v = 25\,000 - 3000$$

$$\bullet \quad v = 22\,000\text{cm}^3$$

Total Volume

$$\bullet \quad 42072.85985\text{cm}^3$$

$$\bullet \quad 42072.85985 \div 10^6 = 0.042\text{m}^3 \text{ (3d.p.)}$$

3. If the castle is made from a mixture of water and sand in the ratio 1:4, what is its mass? Give your answer to 3 decimal places.

$$\text{Total volume} = 0.042\text{m}^3$$

Ratio 1:4

$$1 + 4 = 5$$

$$\frac{0.0421}{5} = 0.00842$$

$$1 \text{ part} = 0.00842$$

$$4 \text{ parts} = 0.00842 \times 4$$

$$4 \text{ parts} = 0.03368$$

$$\text{Density of water} = 1000 \text{ kg/m}^3$$

$$\text{Density of sand} = 1602 \text{ kg/m}^3$$

$$\text{Mass} = \text{density} \times \text{volume}$$

$$0.00842 \times 1000 = 8.42$$

$$0.03368 \times 1602 = 53.95536$$

$$\text{Total mass} = 62.375\text{kg} \text{ (3d.p.)}$$



4. Sanjay makes the castle as shown from a mixture of water and sand in the ratio 1:4. His friend Burt makes the castle without one of the cylindrical towers from a mixture of water and sand in the ratio 1:6. Which castle has the greatest mass?

$$\text{Volume} = 42\,072.85985 - 7602.654222$$

$$\text{Volume} = 34\,470.20563\text{cm}^3$$

$$\text{Volume} = 0.0344\dots\text{m}^3$$

Ratio 1:6

$$1 + 6 = 7$$

$$\frac{0.0344\dots}{7} = 0.00492\dots \text{ for 1 part}$$

$$0.00492\dots \times 6 = 0.02954\dots \text{ for 6 parts}$$

Mass:

$$0.00492\dots \times 1000 = 4.924\dots$$

$$0.02954\dots \times 1602 = 47.332\dots$$

$$\text{Total mass} = 52.256\text{kg (3d.p.)}$$

Conclusion:

Sanjay's castle weighs 62.375kg.

Burt's castle weighs 52.256kg.

Sanjay's sandcastle has a greater mass than Burt's.

